

4-MultiP Description



4-MultiP is a household multipurpose robot of four DoF which the main pursuit is to assist some fast—home daily activities that consume a lot of time for the family members like tidying the garbage kitchen; clearing the table; filling up cups with boiling drinks as well as other classical tasks which require attention and could be dangerous for the users. Its ergonomics design lets us either to use its mobile platform or to fix it on the “battle field”, The base has the teach pendant for programming the desired task to be performed.

1. BSc. Manuel Alejandro Lugo Villeda*~; **logan_wolvmen@hotmail.com**
2. BSc. Héctor de Jesús Velázquez Calderón*
3. PhD. Gustavo Nuñez Esquer*
4. PhD Student. Luis Ivan Lugo Villeda**, **l.lugovilleda@sssup.it**

*Universidad Politécnica de Pachuca, Mechatronics Division, Mex.

**Scuola Superiore Sant’Anna, Italy, Perceptual Robotics, Italy.

~Corresponding Author.

4-MultiP Functions

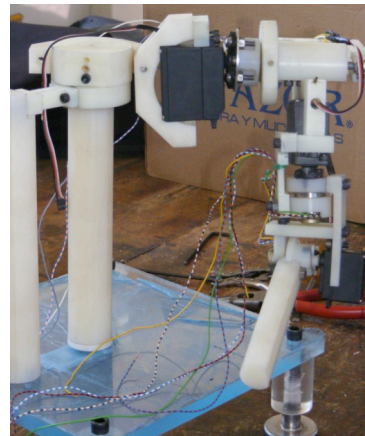

Services

- Tidying the garbage kitchen.
- Clearing the table.
- Filling up cups with boiling drinks.
- Classify small objects with the use of active web camera like broken parts of a piece.
- Cutting vegetables in small pieces
- Iron Function.

Functions

- Easy to use and programming
- Light-Weight.
- Taking apart.

4-MultiP Planning Activities



Implementation

- Mechatronics integration philosophy.
- The CAD/CAM/CAE is actually done.
- Five-month program for getting the 4MultiP working.
- User's manual guide comes with this robot for its easy use.

•Technology

- Made on light-weight material.
- Servomotors.
- DsPics and several kind of sensors.
- Webcam integrated.
- Tasks previously defined
- Mobile and Fixed Platform Mode.
- Force and position control

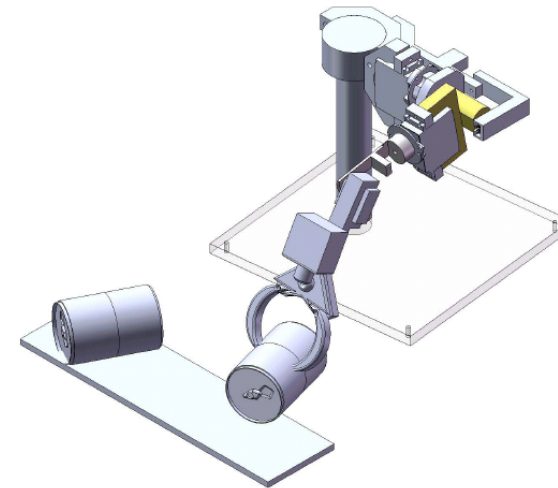

Estimated Price*:

250 €

This total amount was calculated on the basis of commercial parts given in USD dollars plus the spent money on the preliminary prototype construction.